



Engine
Power Source
Rated Load
Rated Power

Xinchai
Diesel
3,500 kg
45 kW @ 2,500 rpm

CPCD35
E-SERIES
FORKLIFT

CPCD35 SPECIFICATIONS >>>

GENERAL

Model	CPCD35
Options	E
Power Type	Diesel
Rated Capacity	3,500 kg
Rated Load Center	500 mm
X Front Overhang, Std. 2-stage Mast	479.5 mm
Y Wheelbase	1,760 mm

WEIGHT

Service Weight	4,630 kg
Axle Loading (Loaded, Front/Rear)	7,310/820 kg
Axle Loading (Unloaded, Front/Rear)	1,765/2,865 kg

TIRES

Tire Type (Front/Rear)	Pneumatic
Front Tire Size	28×9-15-14PR
Rear Tire Size	6.50-10-10PR
Number of Wheels (Front/Rear) (x=Drive Wheels)	2×/2
b ₁₀ Front Tread	1,000 mm
b ₁₁ Rear Tread	980 mm

PERFORMANCE

Travel Speed (Loaded/Unloaded)	18.5/19 km/h
Lift Speed (Loaded/Unloaded)	480/500 mm/s
Lowering Speed (Loaded/Unloaded)	435/480 mm/s
Max. Gradeability (Loaded/Unloaded)	20/20 %

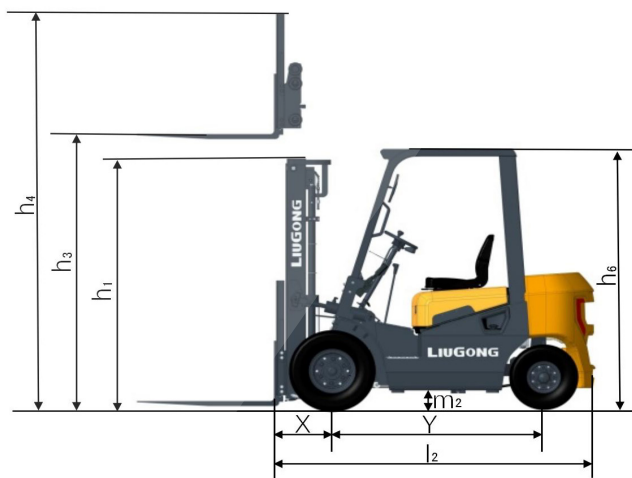

DIMENSIONS

Mast Tilt (FWD/REV)	6/12 deg
h ₁ Height (Upright Lowered), Std. 2-stage Mast	2,110 mm
Free Lift, Std. 2-stage Mast	145 mm
h ₃ Max. Fork Height, Std. 2-stage Mast	3,000 mm
h ₄ Height (Upright Extended), Std. 2-stage Mast	4,146 mm
h ₆ Overhead Guard Height	2,150 mm
Coupling Height	290 mm
l ₂ Length to Fork Face, Std. 2-stage Mast	2,800 mm
b ₁ Overall Width	1,225 mm
Fork Dimensions (Thickness/Width/Length)	50×122×1,070 mm
Fork Carriage (ISO 2328, Class/Type A, B)	3A
Fork Carriage Width	1,100 mm
b ₅ Fork Spread (Min./Max.)	272/1,072 mm
Ground Clearance (Loaded, Below Mast)	135 mm
m ₂ Ground Clearance (Center of Wheelbase)	140 mm
A _{st} Aisle Width (for 1,000×1,200 Pallets, Crossways)	4,176 mm
A _{st} Aisle Width (for 800×1,200 Pallets, Lengthways)	4,346 mm
W _a Turning Radius	2,435 mm

SYSTEMS

Engine Manufacturer	Xinchai
Engine Type	A498BPG-558
Emission Regulation	CN II
Engine Power	45/2,500 kW/rpm
Engine Max. Torque	193/1,800 N·m/rpm
Fuel Tank Capacity	60 L
Shifting Mode	Mechanical
Working Pressure	20.5 MPa
Service Brake/Parking Brake	Hydraulic/Mechanical

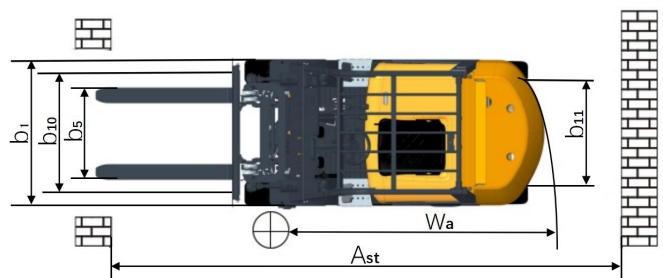

Guangxi Liugong Machinery Co., Ltd.

No. 1 Liutai Road, Liuzhou, Guangxi 545007, PR China
T: +86 772 3886124 E: overseas@liugong.com
www.liugong.com

03/2026 Designed by Liugong

Specifications and designs are subject to change without notice. Machines shown may include optional equipment. Liugong standard and optional equipment may vary from region to region. Please consult your Liugong dealer for information specific to your area. Engine power kW is converted to horsepower (1 kW=1.3596 ps and 1 kW=1.3410 hp) in this file.